

2427

KX-2501A

ADJUSTMENT MANUAL

US Model
Chassis No. SCC-384B-A
Canadian Model
Chassis No. SCC-389B-A



December, 1984

HF CHASSIS

TABLE OF CONTENTS

1. SETUP ADJUSTMENTS		
1-1.	Beam Landing	2
1-2.	Convergence	3
1-3.	Focus	3
1-4.	White Balance	5
2. CIRCUIT ADJUSTMENTS		
2-1.	C Board Adjstments	7
2-2.	K Board Adjustments	8
2-3.	D Board Adjustments	9
2-4.	BA Board Adjustments	12

TRINITRON®
COMPONENT TV
SONY®



MON

SECTION 1 SETUP ADJUSTMENTS

- (1) The following adjustments should be made when a complete realignment is required or a new picture tube is installed.
- (2) These adjustments should be performed with the rated power supply voltage unless otherwise noted.

Controls and switches should be set as follows:

PICTURE control maximum
 BRIGHTNESS control maximum
 (fully clockwise)

Make the following adjustments in the order given.

1. Beam Landing
2. Convergence
3. Focus
4. White Balance

Note: Required Equipment:

1. Color-bar/Pattern Generator
2. Degausser

1-1. BEAM LANDING

Preparation:

- Feed in the white pattern.
- Before starting, degauss the entire screen.

1. Loosen deflection yoke screw.
2. Set purity control as shown in Fig. 1-1.
3. Slide deflection yoke as far forward as it will go.
4. Position neck assembly as shown in Fig. 1-2.
5. Disconnect leads **B** and **G** on the C board.
6. Adjust purity control to center vertical red band as shown in Fig. 1-3.
7. Slide deflection yoke back for a uniform red screen.
8. Check green and blue rasters for uniformity by performing the same way as steps 5, 6 and 7.

To get a uniform green screen, connect lead **G** and disconnect leads **B** and **R** on the C board.

To get a uniform blue screen, connect lead **B** and disconnect leads **R** and **G** on the C board.

After these checks, connect the leads **R**, **G** and **B**.

9. Tighten the deflection yoke screw.
10. Check if mislanding appears at corners a - d as shown in Fig. 1-4. If mislanding is observed, correct it as shown in Fig. 1-4.
11. Confirm that beam landing is correct when the receiver is faced in all directions.

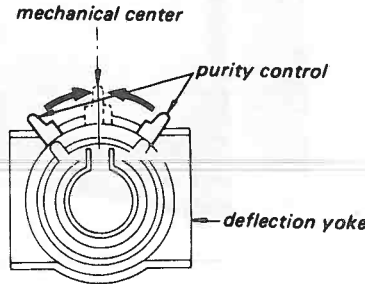

Fig. 1-1

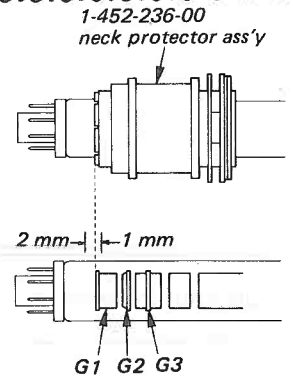

Fig. 1-2

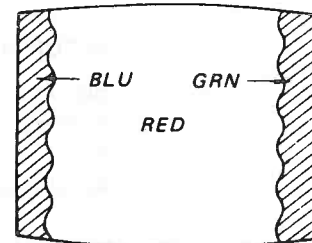

Fig. 1-3

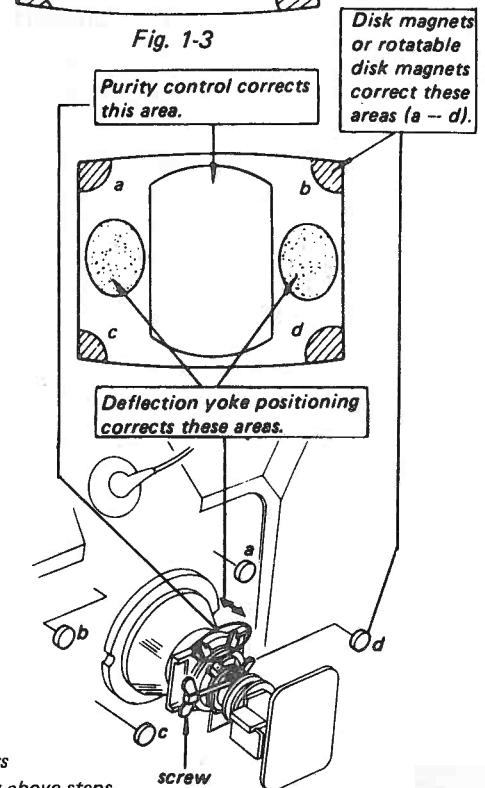
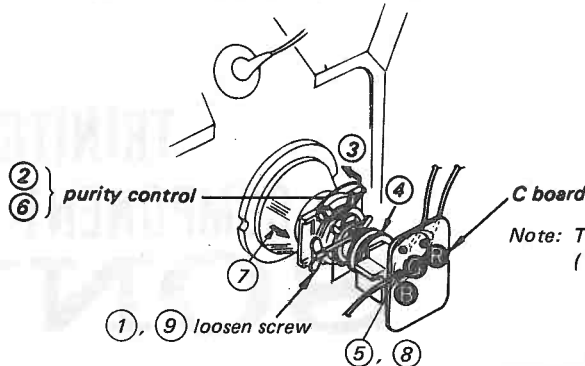

Fig. 1-4



Note: The circled numbers (1 - 10) show above steps.

1-2. CONVERGENCE

Preparation:

1. Feed in a dot or cross-hatch pattern from the color bar generator.
2. Set BRIGHTNESS control and PICTURE (+) (-) control for optimum picture quality.
3. Perform simple landing and white balance adjustment.
4. Make the following adjustments:

- Focus
- horizontal amplitude
- pincushion correction
- pin phase
- vertical amplitude
- vertical linearity (upper/lower pincushion distortion correction)

1. Static Convergence

• **Horizontal Static Convergence**

- 1) Adjust H. STAT to match horizontal convergence in the center of the picture.
- 2) If blue does not move to the direction of best convergence, perform HMC correction.
- 3) As shown in Fig. 1-5 (a), move the BMC magnet so that red, green and blue converge.

• **Vertical Static Convergence**

- 1) Adjust V. STAT to match vertical convergence in the center of the picture.
- 2) If blue does not move to the direction of best convergence, perform VMC correction.
- 3) As shown in Fig. 1-5 (b), move the BMC magnet so that red, green and blue converge.

Note:

- 1) Repeat HMC and VMC adjustments two or three times.
- 2) Reset the focus adjustment if necessary.

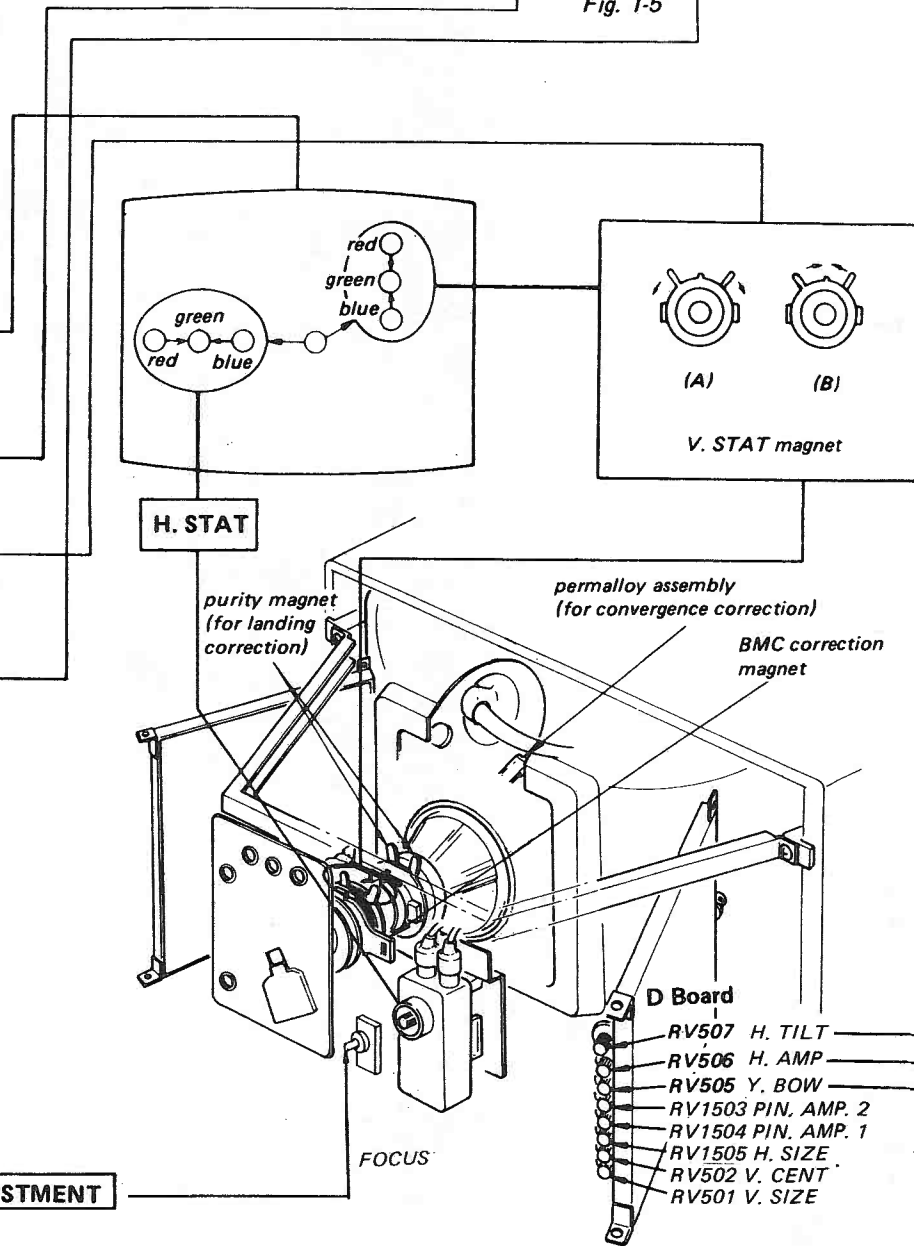
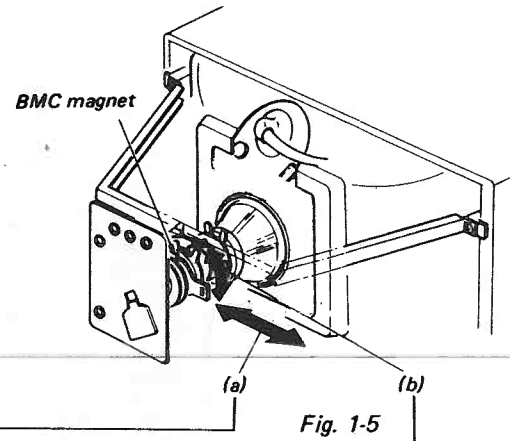

2. Dynamic Convergence

- Perform H. AMP (RV506), H. TILT (RV507), Y. BOW (RV505) as follows.

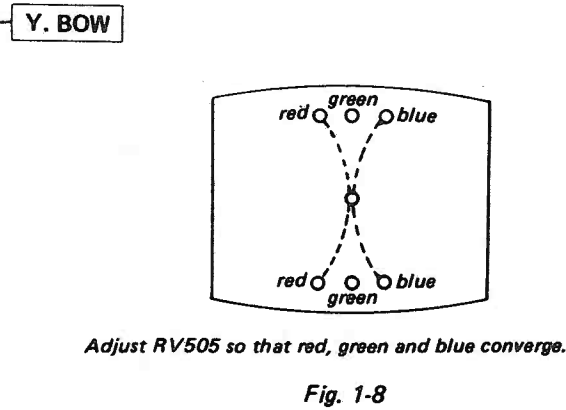
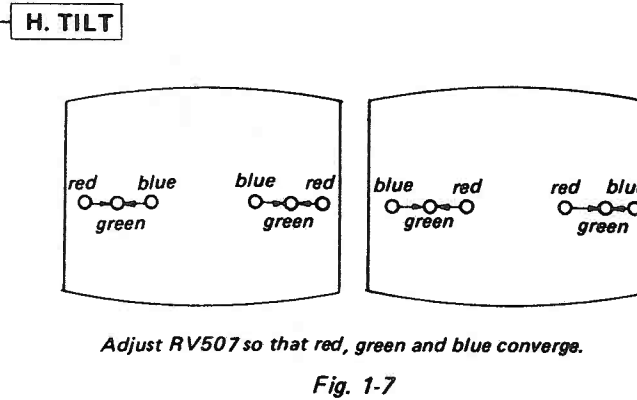
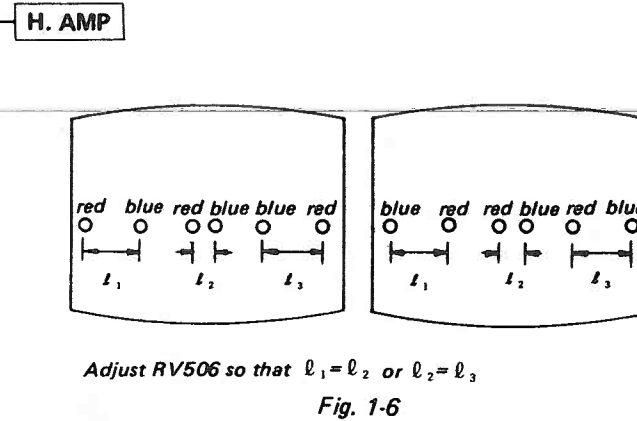

- In the following case, adjust the deflection yoke in the direction shown. After completing the adjustment, fix the DY holder.

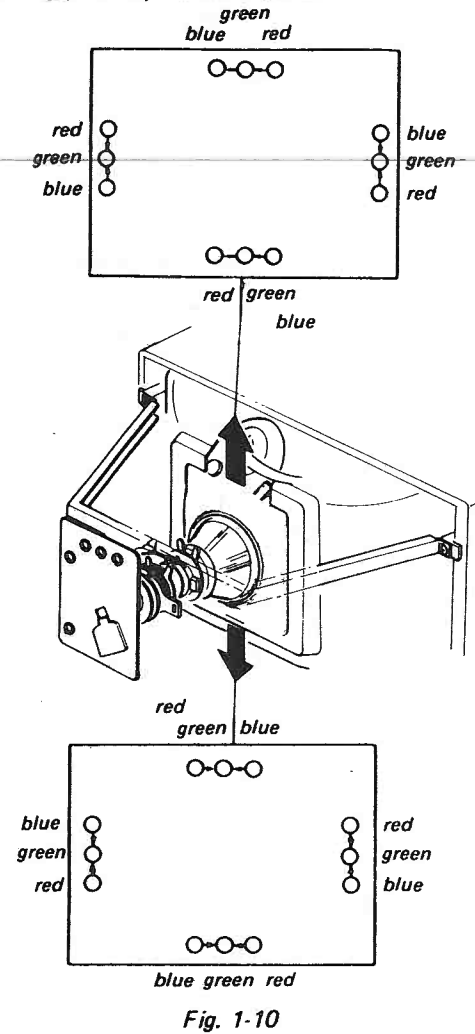

- When there is misconvergence in the corners, insert a permalloy assembly between the deflection yoke corresponding to the misconvergence and the funnel.

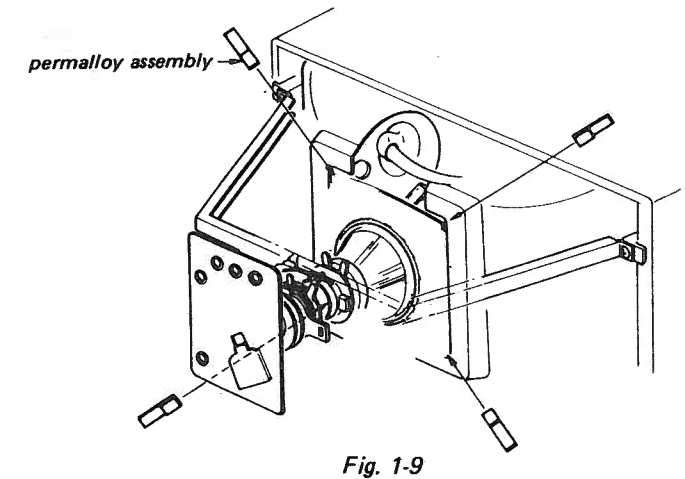

1-3. FOCUS ADJUSTMENT

1. Tune in an RF signal.
2. Set BRIGHTNESS control and PICTURE control for optimum picture quality.
3. Obtain vertical synchronization.
4. Turn FOCUS control to obtain optimum focus over the entire picture.

BD BOARD

pu
ft
co

RV702
B-BKG

RV70
SUB I

2. Dynamic Convergence

- Perform H. AMP (RV506), H. TILT (RV507), Y. BOW (RV505) as follows.

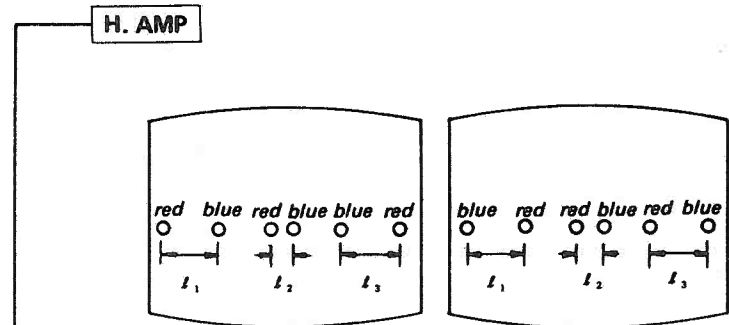

Adjust RV506 so that $l_1 = l_2$ or $l_2 = l_3$

Fig. 1-6

H. TILT

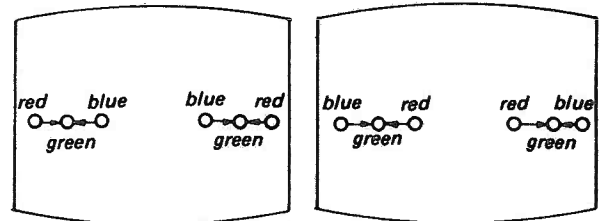

Adjust RV507 so that red, green and blue converge.

Fig. 1-7

Y. BOW

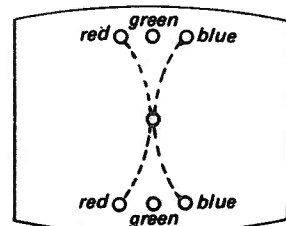

Adjust RV505 so that red, green and blue converge.

Fig. 1-8

- In the following case, adjust the deflection yoke in the direction shown. After completing the adjustment, fix the DY holder.

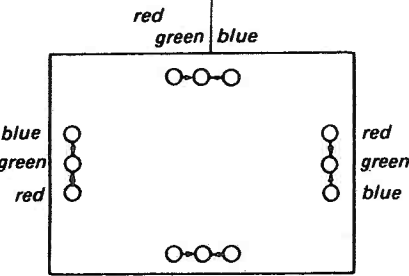
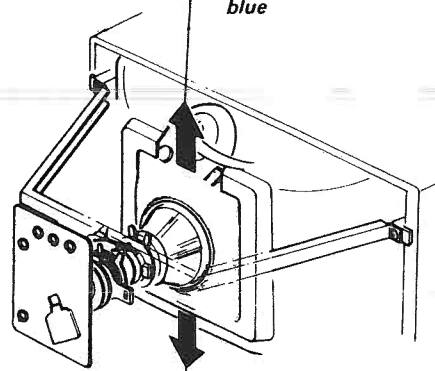
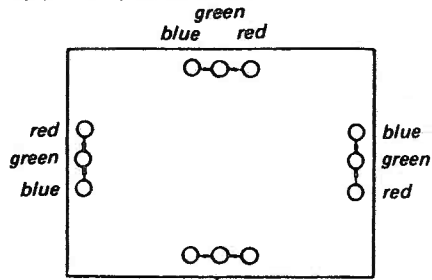

Fig. 1-10

- When there is misconvergence in the corners, insert a permalloy assembly between the deflection yoke corresponding to the misconvergence and the funnel.

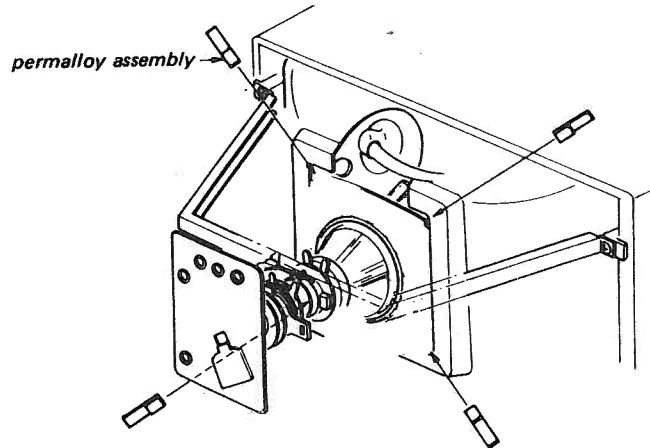
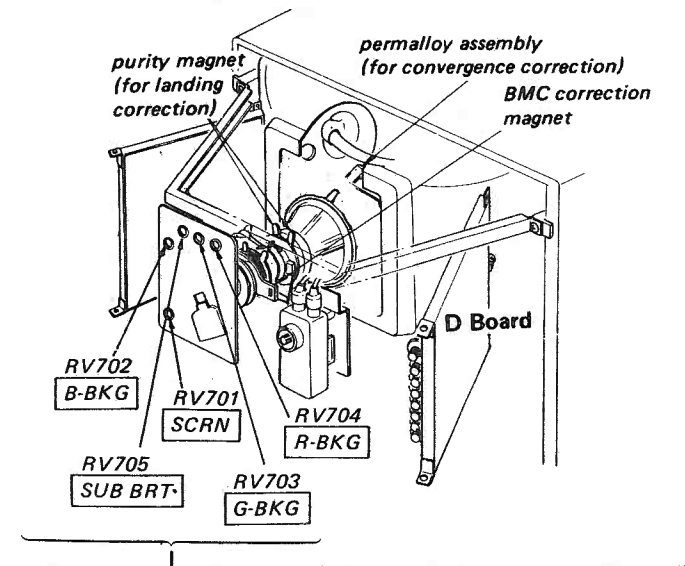
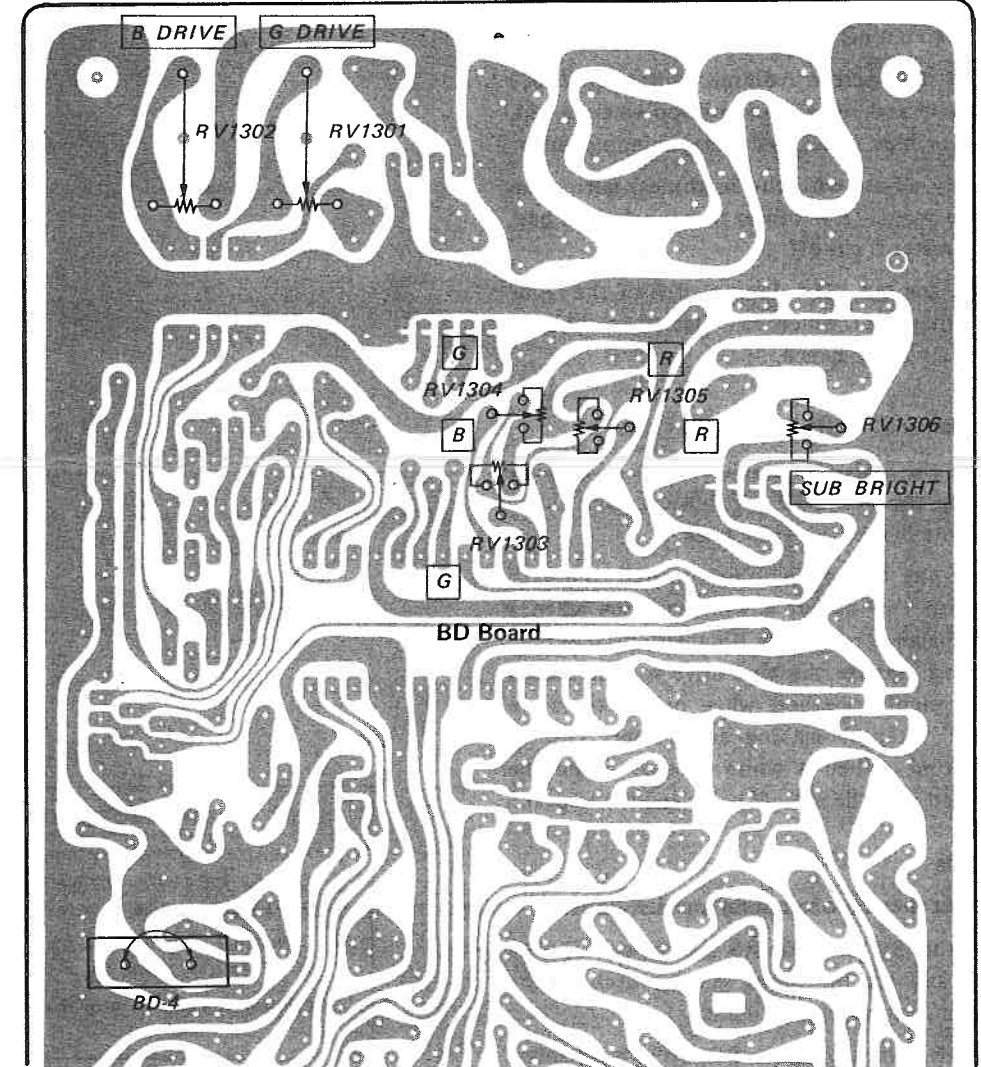

Fig. 1-9

BD BOARD ADJUSTMENTS



1-4. WHITE BALANCE

Preparation

- Receive broadcast and rotate the COLOR volume switch counterclockwise to show black and white pictures.
- Short both ends of the dynamic color terminal (BD-4 connector) on the BD Board.

1. White Balance Near Cut Off Point

- 1) Rotate the drive volume switches (RV1301 and RV1302) clockwise fully.
- 2) Set the cut off volume switches (RV702, RV703, and RV704) to the mechanical center.

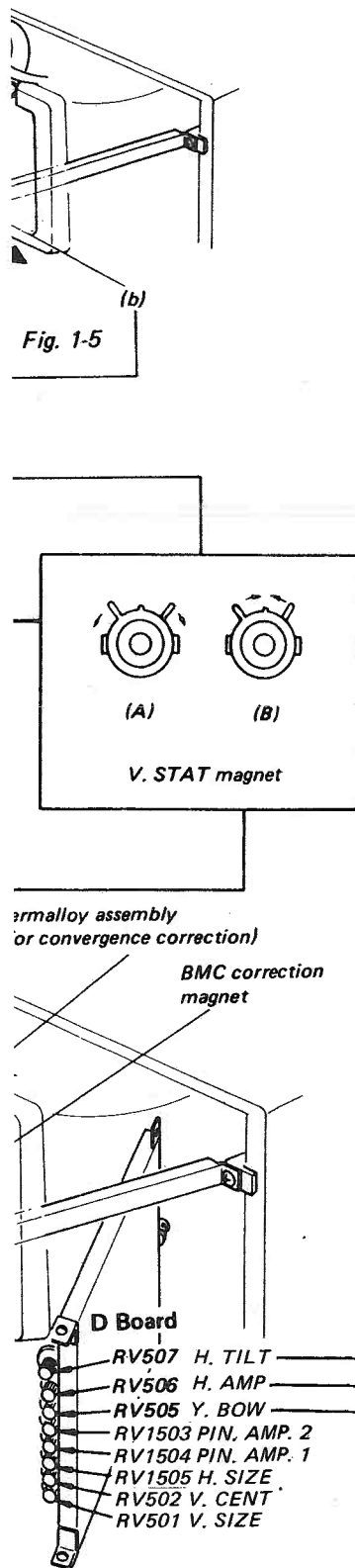

SECTION 2 CIRCUIT ADJUSTMENTS

- 3) Rotate the BRIGHT knob counterclockwise fully and continue pressing the PICTURE (-) button to cut off the picture.
- 4) Rotate the screen volume switch (RV701) clockwise and set at the position where a red, green, or blue raster first starts shining dimly.
- 5) Roughly adjust with the brightness correction volume switch (RV705) so that the darkest part of the raster is cut off.
- 6) Rotate the cut off volume switch of the color other than that which first started to shine to obtain a white balance.

2. White Balance at White Peak

- 1) Rotate the BRIGHT knob clockwise fully, keep pressing the PICTURE (+) button, then check the white balance at white peak.
- 2) Rotate the blue drive volume switch to a dark direction and obtain a white balance when a white balance cannot be obtained, such as blue is strong. Rotate the blue drive volume switch in the similar method when other colors are strong. Repeat making adjustments two or three times when a white balance cannot be obtained near the cut off point and white peak.

3. RGB Mode

- 1) Connect the microcomputer and KX-2501A.
- 2) Press the RGB button to set up the "RGB" mode and set the input select switch of the RGB multiconnector to digital.
- 3) PICTURE initial set. BRIGHT mechanical center (click position).
- 4) Show characters all over the screen and rotate RV1303 through 1305 on the BD Board so that the characters become white all over the screen to obtain a white balance.
- 5) Rotate the brightness correction volume switch (RV1306) and make a rough adjustment so that the darkest part of the raster is cut off.

*Disconnect the jumper wire on the BD Board after making the adjustment.

Note: (1) TEST EQUIPMENT REQUIRED

1. Oscilloscope
2. Digitalmultimeter
3. Color-bar/pattern generator
4. Audio generator

(2) INPUT SIGNAL

When making these adjustments, supply a cross-hatch, color-bar or an off-air signal.

(3) CONTROL SETTINGS

Controls and switch should be set as follows when making checks and adjustments unless otherwise noted.

- PICTURE control
- BRIGHTNESS control Set for best picture.
- COLOR control
- HUE
- V. HOLD Set for stable picture.

- (4) These adjustments should be performed with the rated power supply voltage unless otherwise noted.

Adjustment	Circuit Board	Page
BRIGHTNESS CORRECTION	C	7
BALANCE AND GAIN	K	8
HOLD DOWN LEFT/RIGHT PINCUSHION CORRECTION H. SIZE HV CORRECT HORIZONTAL SYNC UPPER/LOWER PINCUSHION CORRECTION V. SIZE V. CENT B+ VOLTAGE	D	9,10,11
COMB LINE FILTER COLOR SYNC 3.58 MHz TRAP ACC AND HUE CENTER NOTCH SWITCHING	BA	12,13,14

2-2. K BOA

BALANCE

1. Input a 4
2. Connect t
3. Set RV12

L and R Outp

Apply V₁
puts become
reverse and i
waveform lin

Gain Adjustn

Apply V₂
outputs becc
equal, adjust

2-1. C BOARD ADJUSTMENTS

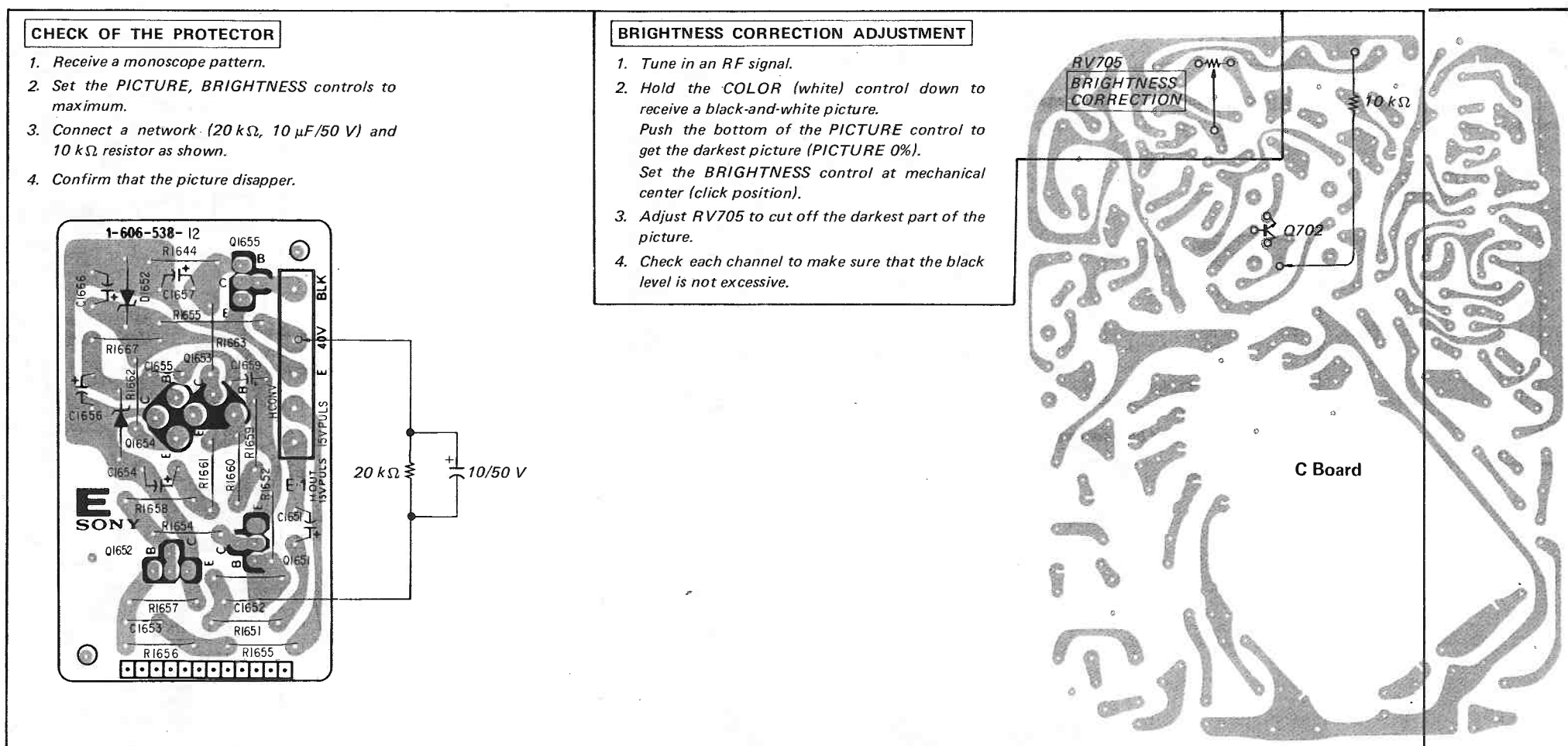

SECTION 2 CIRCUIT ADJUSTMENTS

Note: (1) TEST EQUIPMENT REQUIRED

1. Oscilloscope
2. Digitalmultimeter
3. Color-bar/pattern generator
4. Audio generator

(2) INPUT SIGNAL

When making these adjustments, supply a cross-hatch, color-bar or an off-air signal.

(3) CONTROL SETTINGS

Controls and switch should be set as follows when making checks and adjustments unless otherwise noted.

- PICTURE control
- BRIGHTNESS control Set for best picture.
- COLOR control
- HUE
- V. HOLD Set for stable picture.

- (4)** These adjustments should be performed with the rated power supply voltage unless otherwise noted.

Adjustment	Circuit Board	Page
BRIGHTNESS CORRECTION	C	7
BALANCE AND GAIN	K	8
HOLD DOWN	D	9,10,11
LEFT/RIGHT PINCUSHION CORRECTION		
H. SIZE		
HV CORRECT		
HORIZONTAL SYNC		
UPPER/LOWER PINCUSHION CORRECTION		
V. SIZE V. CENT	BA	12,13,14
B+ VOLTAGE		
COMB LINE FILTER		
COLOR SYNC		
3.58 MHz TRAP		
ACC AND HUE CENTER		
NOTCH SWITCHING		

2-1. C BOARD ADJUSTMENTS

BRIGHTNESS CORRECTION ADJUSTMENT

1. Tune in an RF signal.
2. Hold the COLOR (white) control down to receive a black-and-white picture. Push the bottom of the PICTURE control to get the darkest picture (PICTURE 0%). Set the BRIGHTNESS control at mechanical center (click position).
3. Adjust RV705 to cut off the darkest part of the picture.
4. Check each channel to make sure that the black level is not excessive.

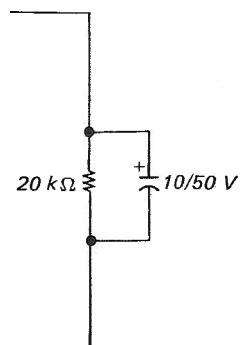
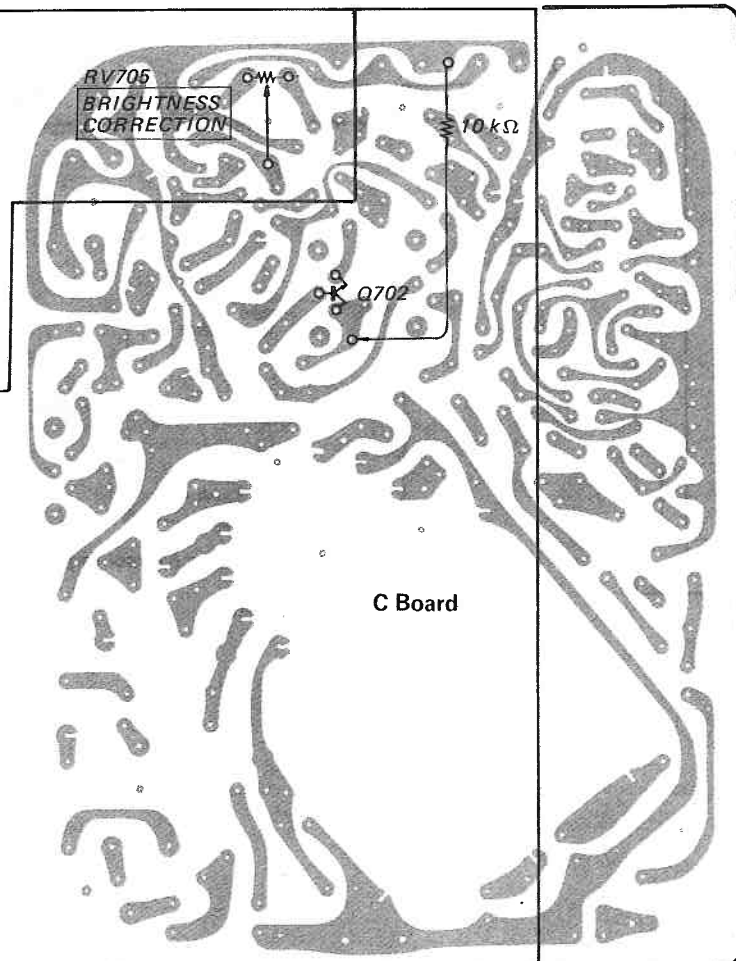

2-2. K BOARD ADJUSTMENTS

BALANCE AND GAIN ADJUSTMENT

1. Input a 400 Hz sine wave 436 mV (-5 dB) to L and R.
2. Connect to an 8 Ω speaker as a load.
3. Set RV1201 and RV1202 to the mechanical center.

L and R Output Balance Adjustment

Apply V₁ and adjust RV1202 so that the L and R outputs become equal. (Input both outputs to an oscilloscope, reverse and add one, then adjust with RV1202 to make the waveform linear.)

Gain Adjustment

Apply V₂ and adjust with RV1201 so that both L and R outputs become 6.34 V. If the L and R outputs are not equal, adjust the level of the lower output to 6.34 V.

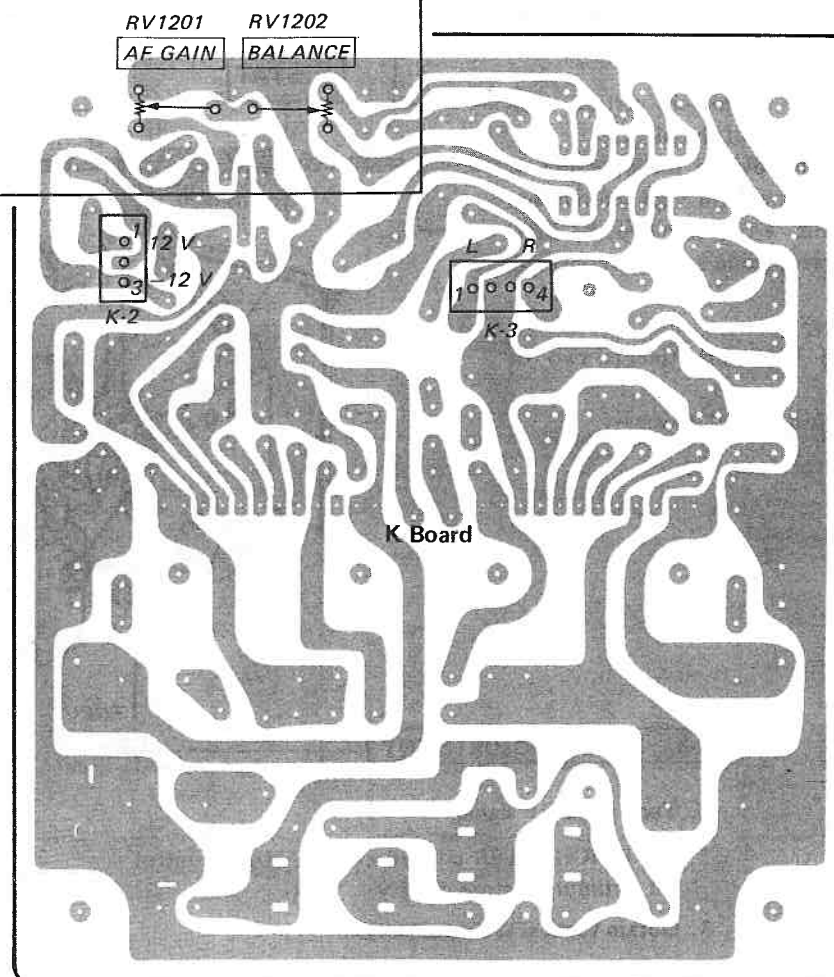
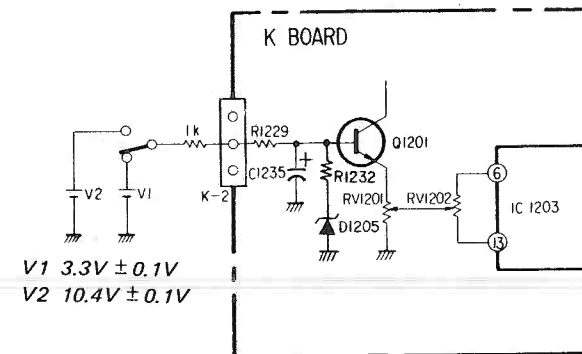

2-3. D BOARD ADJUSTMENTS

R1602 ADJUSTMENT

When replacing the following components, make this adjustment.

R1584, R1593, R1595, R1596, R1597, R1598, R1599, R1600, R1601, R1602, R1603, R1604, R1605, R1606, R1607, R1608, R1609, R1610, D1529, D1530, D1532, Q1513, Q1514, Q1517, Q1518, Q1519, Q1520

1. Feed in a dot pattern signal from patter generator.
2. Set the variable auto-transformer to 120V ac and PICTURE, BRIGHT controls to minimum.
3. Supply the $16.11 \pm 0.01V$ dc to the terminal of D-29 1 with the regulated-dc power supply and confirm that the HV hold down circuit operates. (When the HV hold down circuit operates, raster disappears.)
Note: As soon as the HV hold down circuit operates, turn the POWER switch to OFF.

4. Supply the $15.95 \pm 0.01V$ dc to the terminal of D-29 ① and confirm that the set is normally operated.
5. Receive a white pattern.
6. Set the PICTURE, BRIGHTNESS controls to maximum.
7. Supply the $15.54 \pm 0.01V$ dc to terminal of D-29 ① and confirm that the HV hold down circuit operates.
8. Supply the $15.38 \pm 0.01V$ dc to the terminal of D-29 ① and confirm that the set is normally operated.
9. If step 1 - 8 are not satisfied, select the resistance value of R1602 and repeat above step.
10. Receive a dot pattern.
11. Set BRIGHTNESS control to 50%, PICTURE control to minimum.
12. Conform that emitter voltage of Q1518 is within 12.75 ~ 14.30V dc.

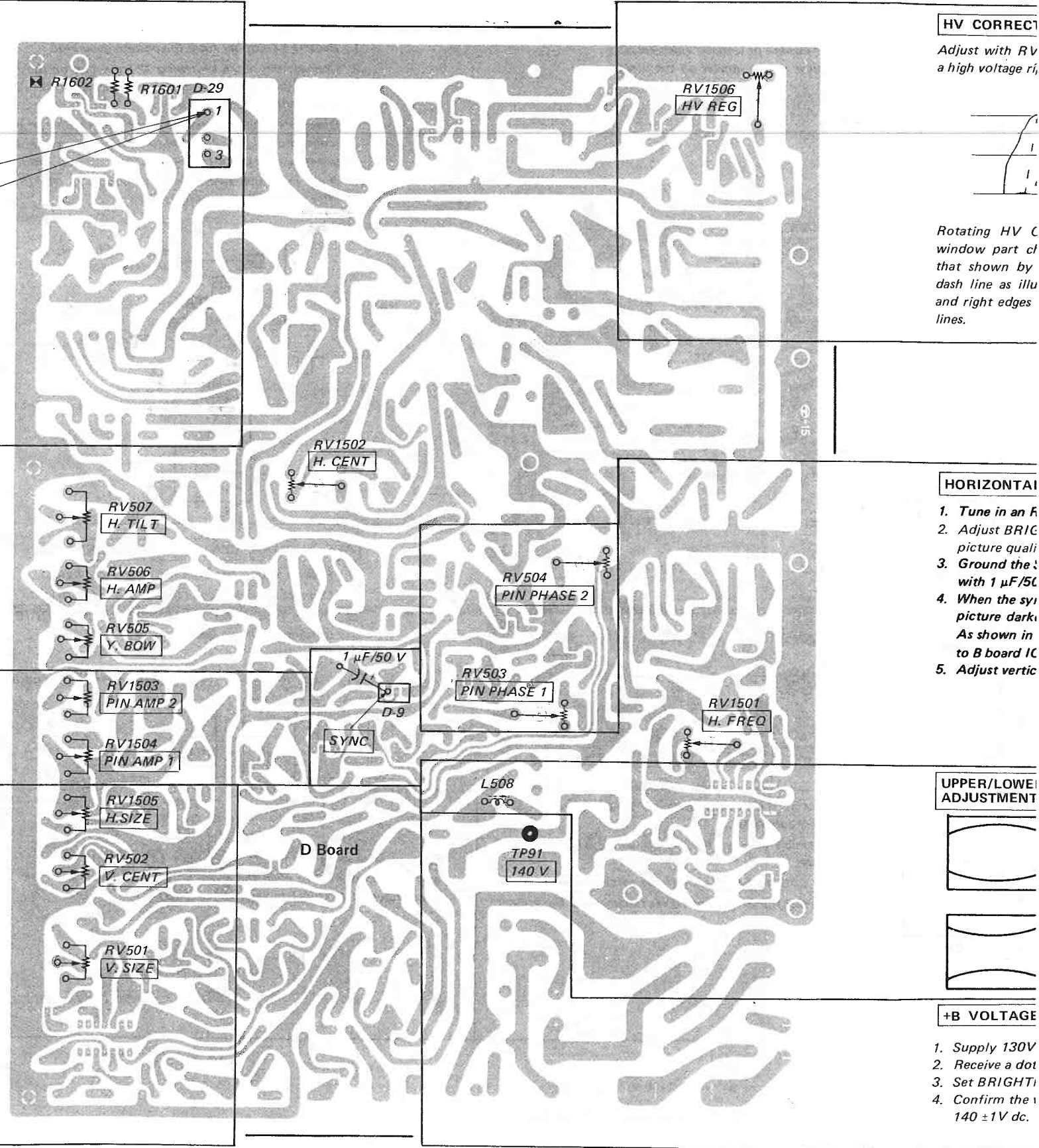
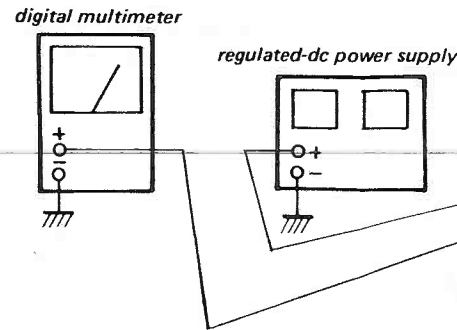

HV CORRECT

Adjust with RV1506 a high voltage regulator.

Rotating HV correct window part of that shown by dash line as illustrated and right edges lines.

LEFT/RIGHT PINCUSHION CORRECTION ADJUSTMENT

1. Rotate PIN AMP 1VR (RV1504) and PIN AMP 2VR (RV1503) counterclockwise fully.
Adjust PIN PHASE 1VR (RV503) to make A and B at the upper and lower ends become equal.

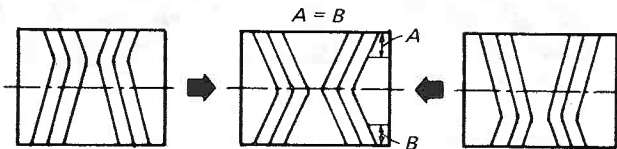

3. Adjust with PIN PHASE 2VR (RV504) when there is a trapezoidal or anti-trapezoidal distortion.

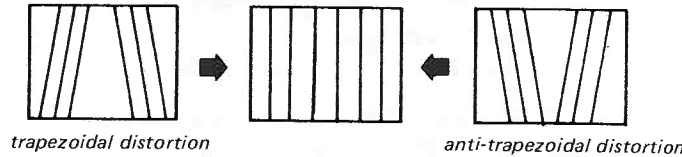

4. When the distortion becomes as shown below, adjust with PIN PHASE 1 (RV503), rotate PIN AMP 2 (RV1503) counterclockwise, then adjust with PIN AMP 1 (RV1504) while plotting the track.

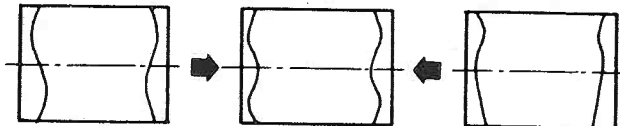

After making an adjustment with PIN PHASE 1 (RV503).

5. When the distortion becomes as shown below, adjust with PIN PHASE 1 (RV503), rotate PIN AMP 2 (RV1503) clockwise, then adjust with PIN AMP 1 (RV1504) while plotting the track.

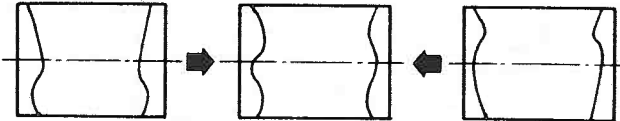

After making an adjustment with PIN PHASE 1 (RV503).

H. SIZE ADJUSTMENT

Rotate RV1505 to obtain the best horizontal line.

V. SIZE AND V. CENT ADJUSTMENT

Rotate RV501 and RV502 to obtain the best vertical line.

HORIZONTAL

1. Tune in an F.
2. Adjust BRIGHTNESS picture quality.
3. Ground the sync with $1 \mu F/50V$.
4. When the sync picture dark, adjust to B board IC.
5. Adjust vertical.

UPPER/LOWER ADJUSTMENT

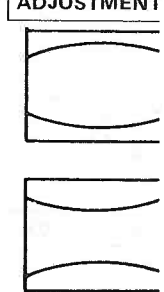

+B VOLTAGE

1. Supply 130V
2. Receive a dot
3. Set BRIGHTNESS
4. Confirm the voltage is $140 \pm 1V$ dc.

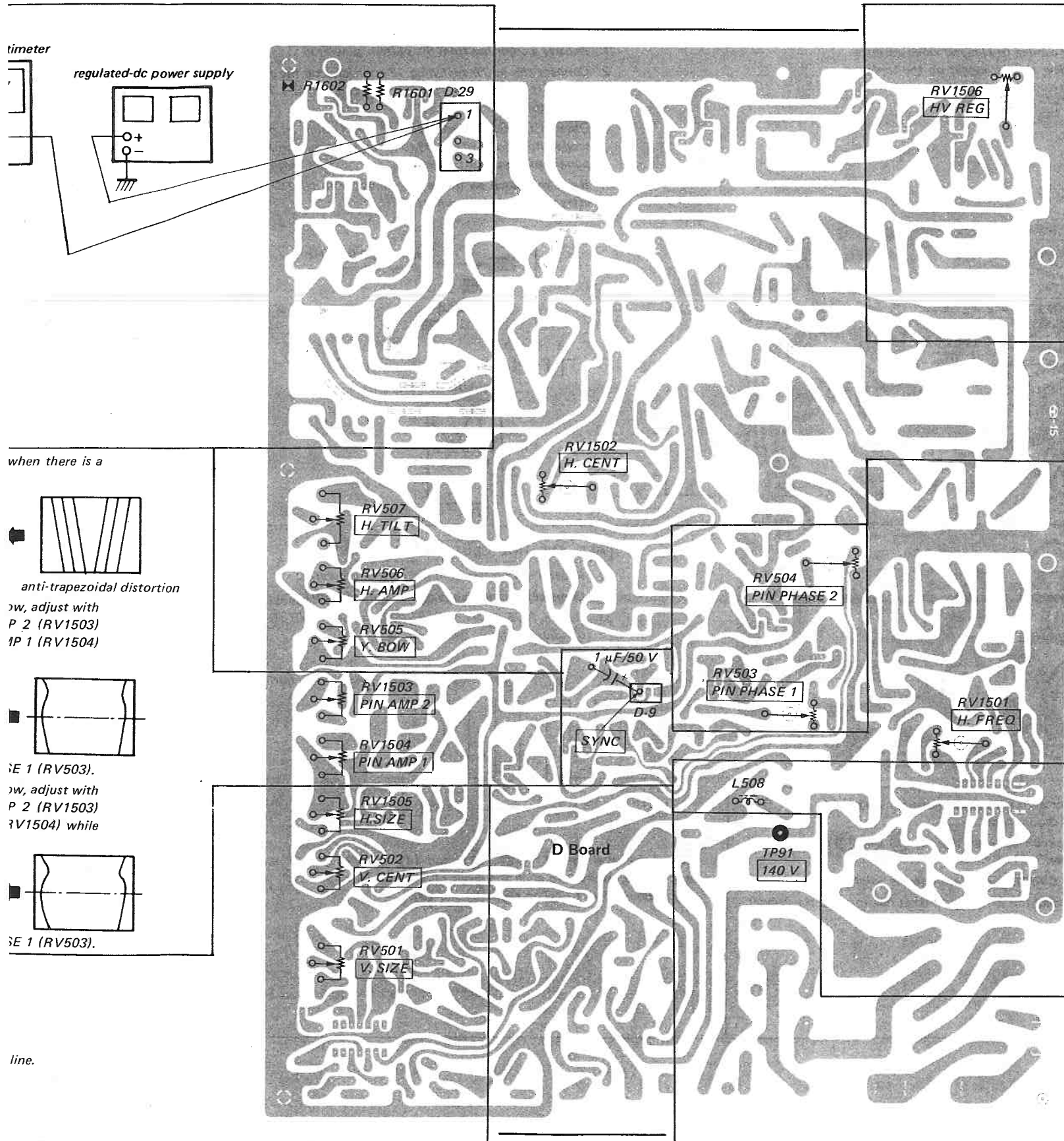

HV CORRECT ADJUSTMENT

Adjust with RV1506 to make the picture distortion best by a high voltage ripple.

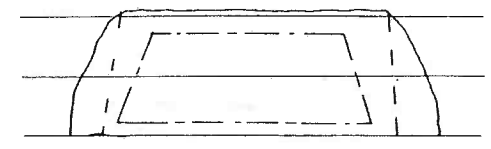

Rotating HV CORRECT (RV1506), the trapezoid of the window part changes from that shown by a solid line to that shown by a broken line and alternate long and short dash line as illustrated above. Adjust so that only the left and right edges approach a straight line as shown by broken lines.

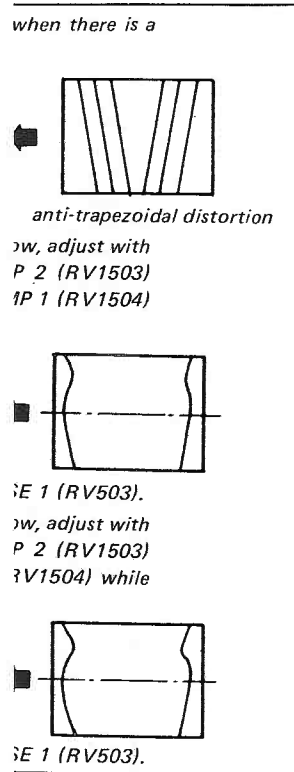

HORIZONTAL SYNC ADJUSTMENT

1. Tune in an RF signal.
2. Adjust BRIGHTNESS control for optimum picture quality.
3. Ground the SYNC terminal of the D-9 connector with 1 μF/50V chemical capacitor.
4. When the sync signal is grounded the picture darkens. As shown in the figure below, add bias to B board IC301 (CX841) pin (14).
5. Adjust vertical sync.

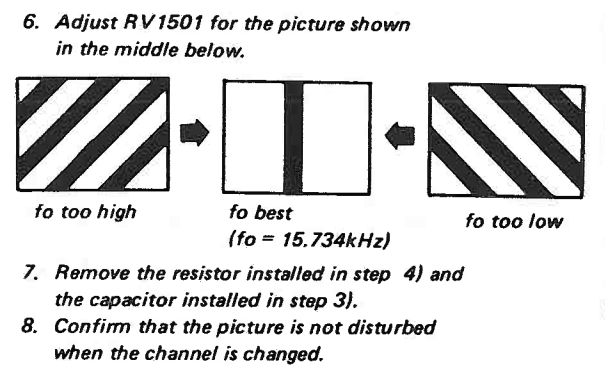
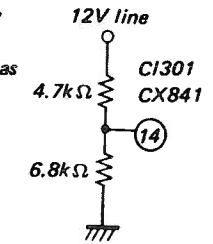

UPPER/LOWER PINCUSHION CORRECTION ADJUSTMENT

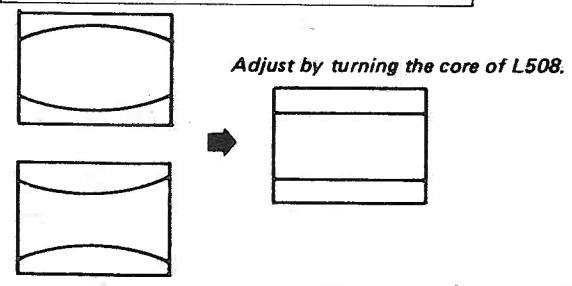

+B VOLTAGE CHECK

1. Supply 130V ac with variable auto-transformer.
2. Receive a dot pattern.
3. Set BRIGHTNESS, PICTURE controls to minimum.
4. Confirm the voltage on digital multimeter is less than 140 ± 1V dc. (+B terminal is TP91 on D board)

2-4. BA BOARD ADJUSTMENTS

COMB LINE FILTER ADJUSTMENT

1. Receive a color bar from the pattern generator.
2. Connect an oscilloscope to the Y signal output terminal (TP52) of the comb line filter and adjust GAIN ADJ (RV301) and PHASE ADJ (L302) to obtain a minimum chroma component in that waveform while plotting the track.

* Check that the notch switching connector is set to OFF before making this adjustment.

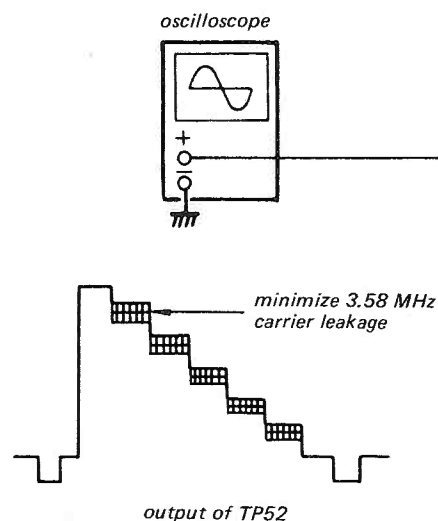

NOTCH SWITCHING

When operating with a color camera or U-matic video cassette recorder connected, if vertical stripes appear on the screen, connect the notch to "ON".

3.58 MHz TRAP ADJUSTMENT

1. Receive a color bar from the pattern generator.
2. Connect the notch switching 1P connector on the ground side of L308 to ON and short both ends of L302 to release the comb line filter.
3. Observe the output waveform of TP53 using an oscilloscope and adjust with L308 to minimize the chroma component of the output waveform.
4. Reset the notch switching 1P connector to NOTCH OFF after making the adjustment.

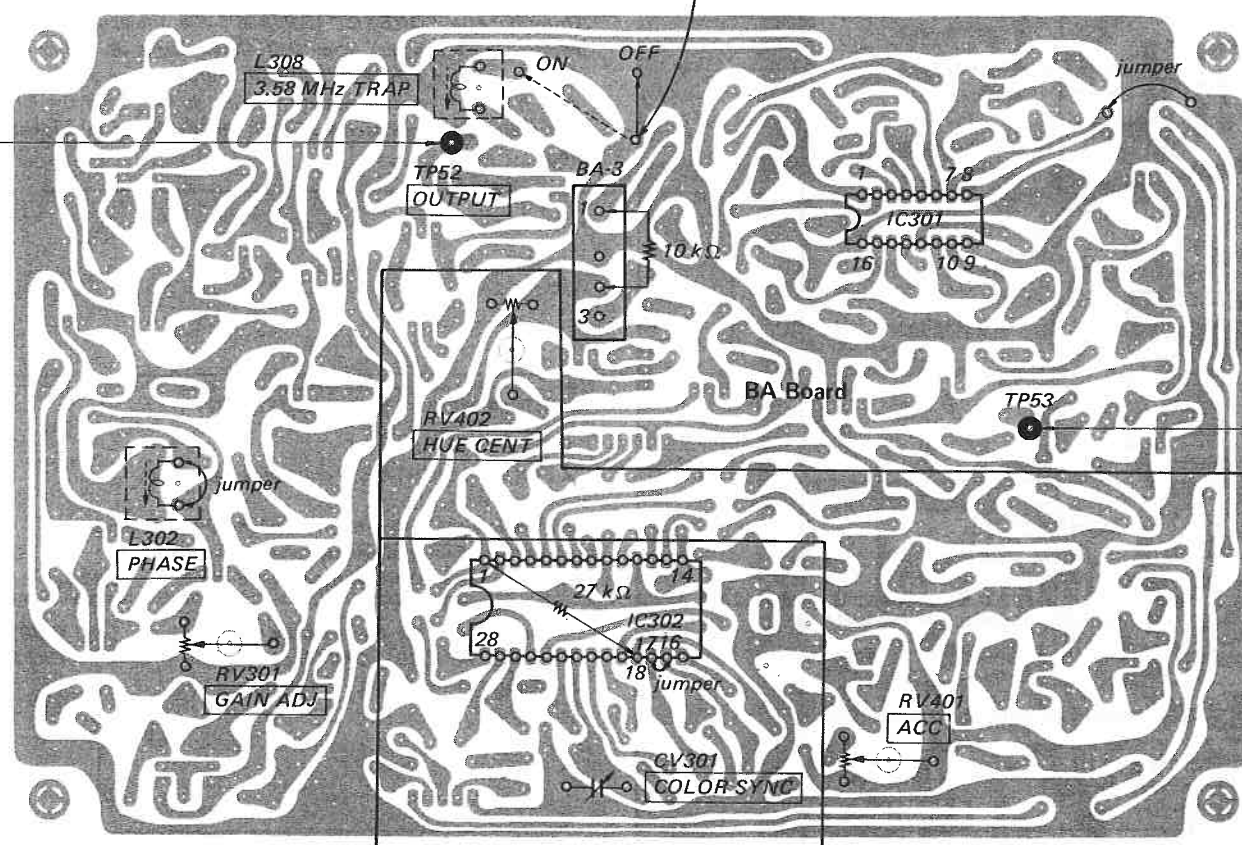
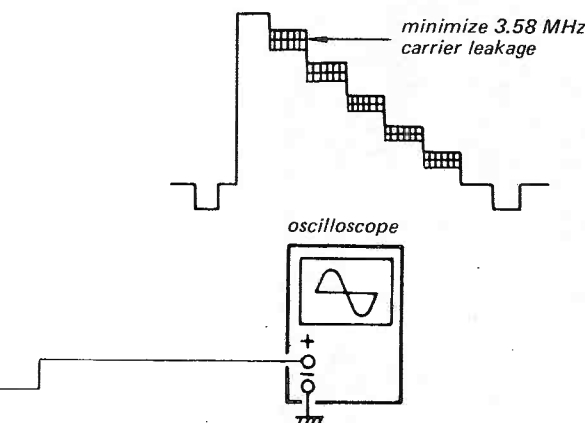

ACC AND HUE CENTER ADJUSTMENT

1. Receive a color bar from the pattern generator.
2. Connect an oscilloscope to pin 27 of IC301.
3. Rotate HUE CENT VR (RV402) and ACC VR (RV401) to adjust as shown below.

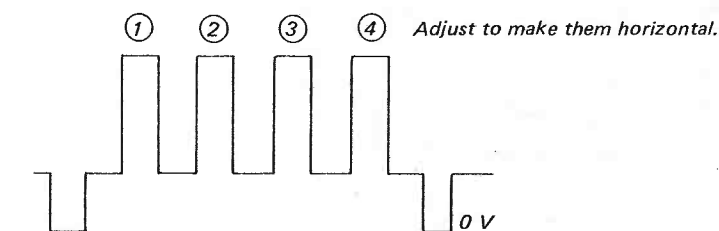

* When the levels of ①, ②, ③, and ④ are not aligned, adjust ACC to align the levels of ① and ④. Then adjust HUE CENT to align ② and ③.

COLOR SYNC

1. Feed in a color-bar signal from the color-bar/pattern generator.
2. Set the switch and controls as shown below.
 COLOR control
 HUE control mechanical center
 PICTURE control maximum
3. Connect a 27 kΩ resistor between the pin 18 and 1 of IC302.
4. Connect a 10 kΩ resistor between the pin 1 and 3 of the BA-3 connector.
5. Short circuit between the pin 16 and 17 of IC302 with a jumper.
6. Adjust CV301 to obtain the stable color picture.
7. Disconnect the 27 kΩ and 10 kΩ resistors and the jumper.

